

## Installing

### Installing



#### Note

If a new unit injector is installed, the appropriate adjustment screw in the rocker arm must also be renewed.

Each time work is performed which requires adjustment of the unit injector, the adjustment screw in the rocker arm and also the unit injector ball stud must be renewed.

New unit injectors are supplied with O-rings and heat shield seal.

- Heat insulating seal and O-rings must be renewed if old unit injector is reused → [Chapter](#).
- Check that the 3 O-rings and the heat shield seal along with securing clip are seated correctly before installing unit injector.



#### Note

The seals must not be twisted.

- Oil the seals and fit the unit injector into the seat in cylinder head with great care.
- Push the unit injector evenly into the cylinder head onto its limit stop.
- Insert tensioning block in slot on side of unit injector.



#### Note

If the unit injector is not at right angles to the tensioning block the securing bolt may loosen and this can damage the unit injector or the cylinder head.

- Therefore align the unit injector as follows.
- Screw new securing bolt into clamping block, but do not tighten (it must still be possible to turn the unit injector slightly).

Position gauge -T10210- between mounting bracket and unit injector as shown.

- Turn unit injector by hand against gauge.
- If necessary, adjust the unit injector and tighten the securing bolt as follows:

12 Nm and + 270° (3/4 turn) further.

(Turning further can be carried out in several stages)

- Fit rocker arm shaft and tighten new securing bolts as follows.

Tighten inner and then both outer bolts – hand-tight. Then using same sequence, tighten to 20 Nm and turn 90° (1/4 turn) further.

- Fit dial gauge onto adjustment screw of unit injector as shown.

Turn crankshaft in direction of engine – rotation until roller of rocker arm is located

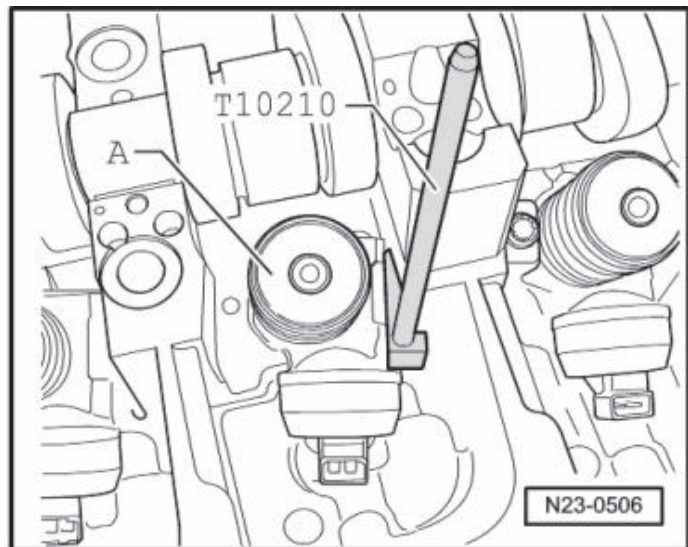

## Removing and installing O-rings for unit injector

### Removing and installing O-rings for unit injector

Special tools and workshop equipment required

t Assembly sleeves -T10056-

#### Removing

- Lever old O-rings very carefully out of unit injector.
- Pay particular attention to ensure that seat of O-ring is not damaged by burrs.

#### Installing

 Note

Always use the assembly sleeves to fit the O-rings. There is a danger of damaging the O-rings if the sleeves are not used.

Gradual introduction of O-rings without different coloured markings. Note the correct allocation of O-rings to grooves: the thickness of the rings reduces towards injector nozzle.

Prevent O-rings from rolling when sliding them on. The O-rings must not be twisted in their seats in unit injector.

- Pull heat shield seal off together with securing clip.
- Clean seating surfaces for O-rings on unit injector very carefully.
  
- Place assembly sleeve -T10056/1- onto stop on unit injector.
- Push the upper, thicker O-ring carefully onto assembly sleeve and into seat on unit injector.
- Remove assembly sleeve.

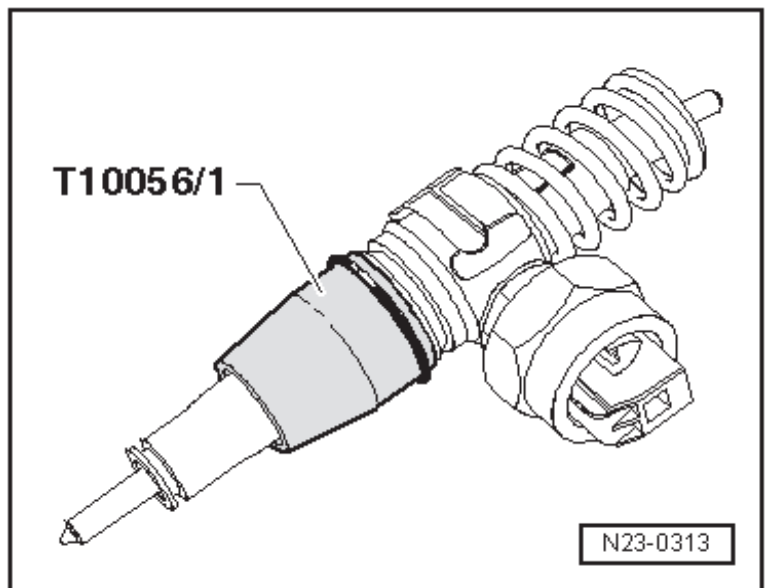
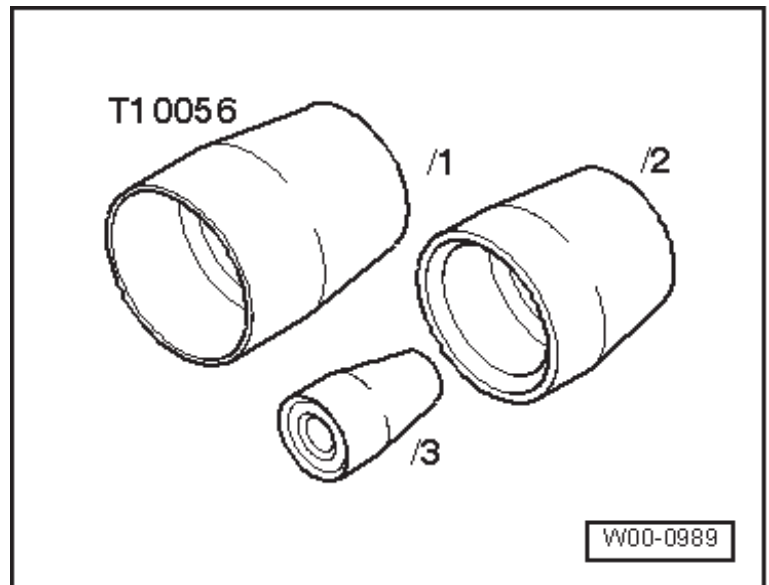

Removing

- Remove cylinder head cover.
- Turn crankshaft until the cam pair point evenly upwards for the unit injector which is to be removed.

Loosen lock nut of adjuster screws -1- and  
 - screw adjuster screws out until the relevant rocker arm lies against the plunger spring of the unit injector.

Remove rocker arm securing bolts -2-  
 - (from outwards to inwards) with socket XZN 10 -3410- and remove rocker arm shaft.

Remove tensioning block securing bolt -3-  
 - with special wrench, long reach -T10054- and remove the block.

Lever connector off unit injector using a  
 - screwdriver. Support opposite side of connector with light finger pressure to prevent canting.

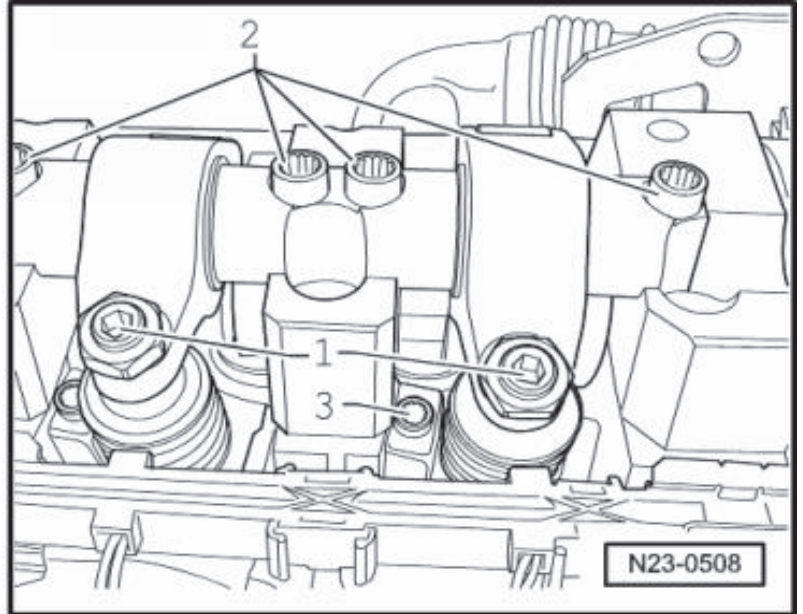

- Seat the puller into the slot on the side of the unit injector instead of the tensioning block.
- Pull unit injector out of cylinder head seat by gently tapping upwards.

